



Academic Services

Academic Upgrading

Physics 20

Study Guide

Updated: November 2015

Important Information about this Study Guide and the Placement Exam

This study guide is designed to prepare students for the Academic Upgrading Physics 20 Placement test. An answer key is included at the end of this guide.

The test is taken in the Testing Centre (MC 221; see www.sait.ca/testing for hours and location). You can receive booking instructions for your testing appointment by e-mailing upgrading@sait.ca, with your SAIT ID number.

It is designed for upgrading placement purposes only. **This exam may not be used for admission to any SAIT program; that is, this is not a SAIT admission exam. In addition, the results cannot be used at any other educational institution.**

The time allotted for the Physics 20 Placement test is 2.5 hours. It consists of 30 questions and covers Grade 11 (Physics 20) material. A mark of 65% is required to pass and allows entrance into PHYS 182. Please note that you should take the Physics 10 Placement test (with a passing grade of 65%) before proceeding to the Physics 20 Placement test.

Note: PHYS 182 is equivalent to Physics 30.

PHYS 182 is accepted as an admission requirement at other post-secondary institutions in Alberta, but you should always check with the post-secondary institution you are interested in attending (if it is not SAIT) to confirm it will accept the course.

SAIT Academic Upgrading Course Sequence

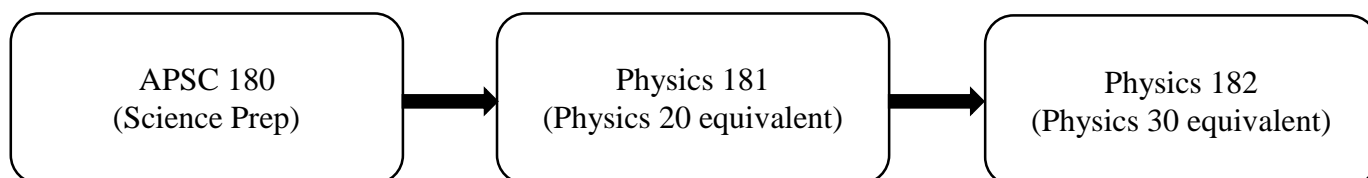

Introduction: Physics 20 Study Guide

- Review the objectives, definitions, and practice exercises.
- You may use the formulas provided on the formula sheet at the end of the guide.
- Check your answers with the answer key provided at the end of this guide.
- You may choose to utilize a Physics 20 Study Guide from the Calgary Public Library or bookstore for extra review.
- You will be given a formula sheet during the exam.
- You will need and are required to bring a scientific calculator for the test (graphing calculators are not permitted).

NOTE: If you are interested in taking an exam that can be used in lieu of the Physics 20 admission requirement for entrance into SAIT programs, you will need to see the Testing website at www.sait.ca/testing for more information about Admission exams.

Copyright information

The source of the materials is <http://education.alberta.ca/>. The use of these materials by SAIT Polytechnic is done without any affiliation with or endorsement by the Government of Alberta. Reliance upon SAIT Polytechnic's use of these materials is at the risk of the end user.

Course Text(s)

Ackroyd, Anderson, et al (2009). *Physics*. Pearson. (ISBN-13: 978-0-13-505048-4)

Learning Aids

Scientific calculator

Physics I – PHYS 181 (PHYS 20)

Course Content

Below is presented a list of the learning modules used to achieve the learning outcome(s) for this course....

1. : Kinematics

Learning Outcome:

Students will describe motion in terms of displacement, velocity, acceleration and time.

Objectives:

1. define, qualitatively and quantitatively, displacement, velocity and acceleration
 2. define, operationally, and compare and contrast scalar and vector quantities.
 3. explain, qualitatively and quantitatively, uniform and uniformly accelerated motion when provided with written descriptions and numerical and graphical data.
 4. interpret, quantitatively, the motion of one object relative to another, using displacement and velocity vectors.
 5. explain, quantitatively, two-dimensional motion in a horizontal or vertical plane, using vector components.
-

2. : Dynamics

Learning Outcome:

Students will explain the effects of balanced and unbalanced forces on velocity.

Objectives:

1. explain that a nonzero net force causes a change in velocity
 2. apply Newton's first law of motion to explain, qualitatively, an object's state of rest or uniform motion.
 3. apply Newton's second law of motion to explain, qualitatively, the relationships among net force, mass and acceleration.
 4. apply Newton's third law of motion to explain, qualitatively, the interaction between two objects, recognizing that the two forces, equal in magnitude and opposite in direction, do not act on the same object.
 5. explain, qualitatively and quantitatively, static and kinetic forces of friction acting on an object.
 6. calculate the resultant force, or its constituents, acting on an object by adding vector components graphically and algebraically.
 7. apply Newton's laws of motion to solve, algebraically, linear motion problems in horizontal, vertical and inclined planes near the surface of Earth, ignoring air resistance.
 8. analyze data and apply mathematical and conceptual models to develop and assess possible solutions
 9. use free-body diagrams to describe the forces acting on an object.
-

Learning Outcome:

Students will explain that gravitational effects extend throughout the universe.

Objectives:

1. identify the gravitational force as one of the fundamental forces in nature.
2. describe, qualitatively and quantitatively, Newton's law of universal gravitation.
3. explain, qualitatively, the principles pertinent to the Cavendish experiment used to determine the universal gravitational constant, G .
4. define the term "field" as a concept that replaces "action at a distance" and apply the concept to describe gravitational effects.

5. relate, qualitatively and quantitatively, using Newton's law of universal gravitation, the gravitational constant to the local value of the acceleration due to gravity
 6. predict, quantitatively, differences in the weight of objects on different planets.
-

3. : Circular Motion, Work and Energy

Learning Outcome:

Students will explain circular motion, using Newton's laws of motion.

Objectives:

1. describe uniform circular motion as a special case of two-dimensional motion.
 2. explain, qualitatively and quantitatively, that the acceleration in uniform circular motion is directed toward the centre of a circle.
 3. explain, quantitatively, the relationships among speed, frequency, period and radius for circular motion.
 4. explain, qualitatively, uniform circular motion in terms of Newton's laws of motion.
 5. explain, quantitatively, planetary and natural and artificial satellite motion, using circular motion to approximate elliptical orbits.
 6. predict the mass of a celestial body from the orbital data of a satellite in uniform circular motion around the celestial body.
 7. explain, qualitatively, how Kepler's laws were used in the development of Newton's law of universal gravitation.
-

Learning Outcome:

Students will explain that work is a transfer of energy and that conservation of energy in an isolated system is a fundamental physical concept.

Objectives:

1. define mechanical energy as the sum of kinetic and potential energy..
2. determine, quantitatively, the relationships among the kinetic, gravitational potential and total mechanical energies of a mass at any point between maximum potential energy and maximum kinetic energy.

3. analyze, quantitatively, kinematics and dynamics problems that relate to the conservation of mechanical energy in an isolated system.
 4. recall work as a measure of the mechanical energy transferred and power as the rate of doing work.
 5. describe power qualitatively and quantitatively.
 6. describe, qualitatively, the change in mechanical energy in a system that is not isolated.
-

4. : Oscillatory Motion and Mechanical Waves

Learning Outcome:

Students will describe the conditions that produce oscillatory motion.

Objectives:

1. describe oscillatory motion in terms of period and frequency.
 2. define simple harmonic motion as a motion due to a restoring force that is directly proportional and opposite to the displacement from an equilibrium position.
 3. explain, quantitatively, the relationships among displacement, acceleration, velocity and time for simple harmonic motion, as illustrated by a frictionless, horizontal mass-spring system or a pendulum, using the small-angle approximation.
 4. determine, quantitatively, the relationships among kinetic, gravitational potential and total mechanical energies of a mass executing simple harmonic motion.
 5. define mechanical resonance.
-

Learning Outcome:

Students will describe the properties of mechanical waves and explain how mechanical waves transmit energy.

Objectives:

1. describe mechanical waves as particles of a medium that are moving in simple harmonic motion.
2. compare and contrast energy transport by matter and by waves
3. define longitudinal and transverse waves in terms of the direction of motion of the medium particles in relation to the direction of propagation of the wave.

4. define the terms wavelength, wave velocity, period, frequency, amplitude, wave front and ray as they apply to describing transverse and longitudinal waves.
 5. describe how the speed of a wave depends on the characteristics of the medium.
 6. predict, quantitatively, and verify the effects of changing one or a combination of variables in the universal wave equation $v = f\lambda$.
 7. explain, qualitatively, the phenomenon of reflection as exhibited by mechanical waves.
 8. explain, qualitatively, the conditions for constructive and destructive interference of waves and for acoustic resonance.
 9. explain, qualitatively and quantitatively, the Doppler effect on a stationary observer of a moving source.
-

Self-Assessment

This assessment is only meant to give students an idea of what the multiple choice questions will look like. Refer to the objectives so that you make sure to study all topic areas.

1. A truck (mass = 2.50×10^3 kg) is traveling at 90.0 km/h on a level road. The driver applies the brakes and decelerates at -3.30 m/s^2 .

Find:

- the time taken for the truck to stop
- the velocity of the truck for the first 8 seconds and fill in the table below

| Time /s | Velocity /ms ⁻¹ |
|---------|----------------------------|
| 1 | |
| 2 | |
| 3 | |
| 4 | |
| 5 | |
| 6 | |
| 7 | |
| 8 | |

- the displacement of the truck when it stops.
- Explain why the velocity of the truck at 8 seconds cannot be -1.4 m/s .

2. A basketball rebounds of the ground with an upward vertical velocity of 20.2 m/s

Find:

- the velocity of the basketball at one second intervals until it hits the ground again.
- the maximum height that the basketball reaches.

3. Find the magnitude and standard angle of the resultant for the following three vectors:

$$A = 20.0 \text{ N @ } 24^\circ$$

$$B = 24.0 \text{ N @ } 270^\circ$$

$$C = 12.0 \text{ N @ } 122^\circ$$

4. A student throws a ball horizontally from the top of the Senator Burns Building. The building is 120.0 m high, and the ball lands 55.0 m from the building. ($g = 9.81 \text{ m/s}^2$)

Find:

- the initial velocity of the ball.
- the velocity, at $t = 2.80 \text{ s}$.

5. You have a mass of 75.0 kg and you are in an elevator and you are standing on a scale that reads your weight on Newtons. If the elevator accelerates downward at 1.90 m/s^2 , what is the scale reading?

6. Two masses A and B are connected by a light cord. Mass B is 4.00 kg and rests on a horizontal table top. There is friction between mass B and the table. The kinetic coefficient is 0.330. Mass A (3.00 kg) hangs over the table edge by means of frictionless pulley and is falling downward at 1.00 m/s at this instant.

Find:

- the velocity when mass A has fallen 2.00 m
- the tension in the cord.

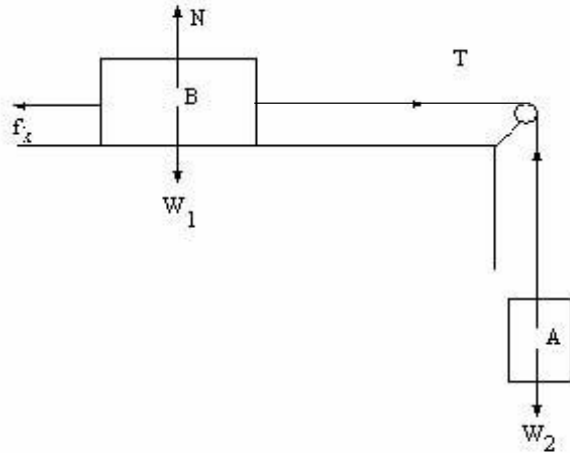

7. Calculate the centripetal acceleration of the Earth in its orbit around the Sun and net force exerted on the Earth. Assume that the Earth's orbit is a circle of radius 1.50×10^{11} m. ($M_{\text{earth}} = 5.97 \times 10^{24}$ kg)

8. A spring ($k = 400.0$ N/m) is initially hung vertically.

- If a 5.000 kg mass is attached to the end of the spring and gently lowered to rest position, how much will the spring extend by?
- If the mass-spring system is placed on a horizontal frictionless surface and the mass is displaced by the amount calculated in part a), determine the maximum velocity of the mass once it is released.
- What will the period of the resulting oscillation be?

9. On a warm day, a rifle bullet is fired across a canyon at a steel target on the other side. The bullet's average horizontal speed is 490.0 m/s. If the sound of the bullet striking the target is heard 11.7 s after it is fired, how wide is the canyon? (*speed of sound in air at 30°C = 331 m/s*)

10. You are riding on the C-Train on a warm (30° C) day in July. The windows are open and you can hear the "clang clang" of the crossing bell on 36th Street. The normal frequency of the bell is 600.0 Hz. The speed of the train as it passes the crossing 90.0 km/h. What **change** in frequency is observed from when you approach the crossing bell to when you are moving away from the crossing bell? (*Speed of sound in air at 30°C = 331 m/s*)

11. Robert pushes a lawn mower on a level lawn with a constant force of 200.0 N at an angle of 30° to the horizontal. How far does he push the mower in doing 1440 J of work?

12. A girl swings back and forth on a swing with ropes that are 4.00 m long. The maximum height she reaches is 2.00 m above the ground. At the lowest point of the swing, she is 0.500 m above the ground. What is the girl's maximum speed at the bottom of the swing?

ANSWERS

1.

a) 7.58 s

b)

| Time /s | Velocity /m/s |
|---------|---------------|
| 1 | 21.7 |
| 2 | 18.4 |
| 3 | 15.1 |
| 4 | 11.8 |
| 5 | 8.50 |
| 6 | 5.20 |
| 7 | 1.90 |
| 8 | 0.00 |

c) 94.7 m

d) because the brakes cause the truck to reach a stop, they will not cause it to reverse or speed up in the opposite direction.

2.

a) 10.4, 0.580, -9.23 -19.0, 0.00 m/s

b) 20.8 m

3.

Resultant = 13.2 m @ 334°

4.

a) 11.1 m/s horizontally only

b) 29.6 m/s $\theta = 68^\circ$ down from horizontal

5.

593 N

6.

a) 3.23 m/s

b) 22.4 N

7.

$a_c = 5.95 \times 10^{-3} \text{ m/s}^2$ toward the sun (centripetal acceleration of Earth)

$F_c = 3.55 \times 10^{22} \text{ N}$ toward the sun (net force producing acceleration)

8.

a) 0.1227 m or 12.27 cm

b) 1.097 m/s

c) 0.7025 s

9.

2.40 km

10.

$\Delta f = 91.0 \text{ Hz}$

11.

8.31 m

12.

5.42 m/s

Physics 20 Placement Test Formula Sheet

Note: use 9.81 m/s^2 for the acceleration due to gravity and $6.67 \times 10^{-11} \text{ N}\cdot\text{m}^2/\text{kg}^2$ for the universal gravitation constant

$$v = \frac{d}{t}$$

$$a = \frac{v_f - v_i}{t}$$

$$v_{ave} = \frac{\Delta d}{\Delta t}$$

$$d = v_i t + \frac{1}{2} a t^2$$

$$d = \left(\frac{v_i + v_f}{2} \right) t$$

$$d = v_f t - \frac{1}{2} a t^2$$

$$a_{ave} = \frac{\Delta v}{\Delta t}$$

$$v_f^2 = v_i^2 + 2ad$$

$$|v_c| = \frac{2\pi r}{T}$$

$$|a_c| = \frac{v^2}{r} = \frac{4\pi^2 r}{T^2}$$

$$F_{net} = ma$$

$$F_c = \frac{mv^2}{r}$$

$$g = \frac{F_g}{m}$$

$$|F_g| = \frac{Gm_1 m_2}{r^2}$$

$$|g| = \frac{Gm}{r^2}$$

$$|F_f| = \mu |F_N|$$

$$F_s = -kx$$

$$E_k = \frac{1}{2} mv^2$$

$$E_p = mgh$$

$$E_p = \frac{1}{2} kx^2$$

$$W = |F||d|\cos\theta$$

$$W = \Delta E$$

$$T = 2\pi \sqrt{\frac{l}{g}}$$

$$T = 2\pi \sqrt{\frac{m}{k}}$$

$$T = \frac{1}{f}$$

$$f_d = f_{source} \left(\frac{v_{sound}}{v_{sound} \mp v_{source}} \right)$$

$$\frac{T_A^2}{r_A^3} = \frac{T_B^2}{r_B^3}$$

$$\% \text{ efficiency} = \frac{W_{out}}{W_{in}} \times 100\%$$